

# **Geometric Dimensioning and Tolerancing - GD&T**

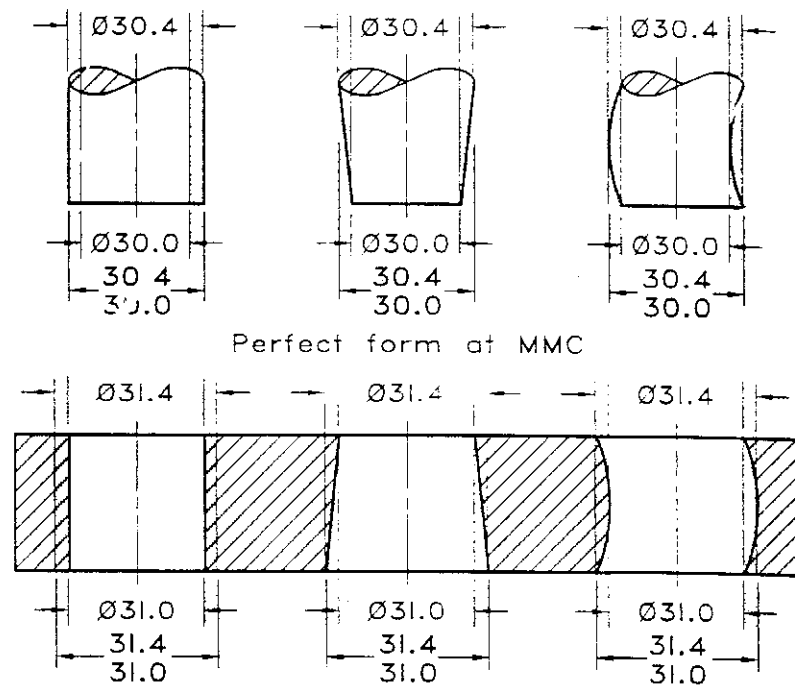

# GD&T

- The need to tolerance more than size led to a more precise system





# GD&T - Example

Technical Drawing 13<sup>th</sup> Edition  
Giesecke, Mitchell, Spencer, Hill Dygdon, Novak, Lockhart

© 2009 Pearson Education, Upper Saddle River, NJ 07458.  
All Rights Reserved.

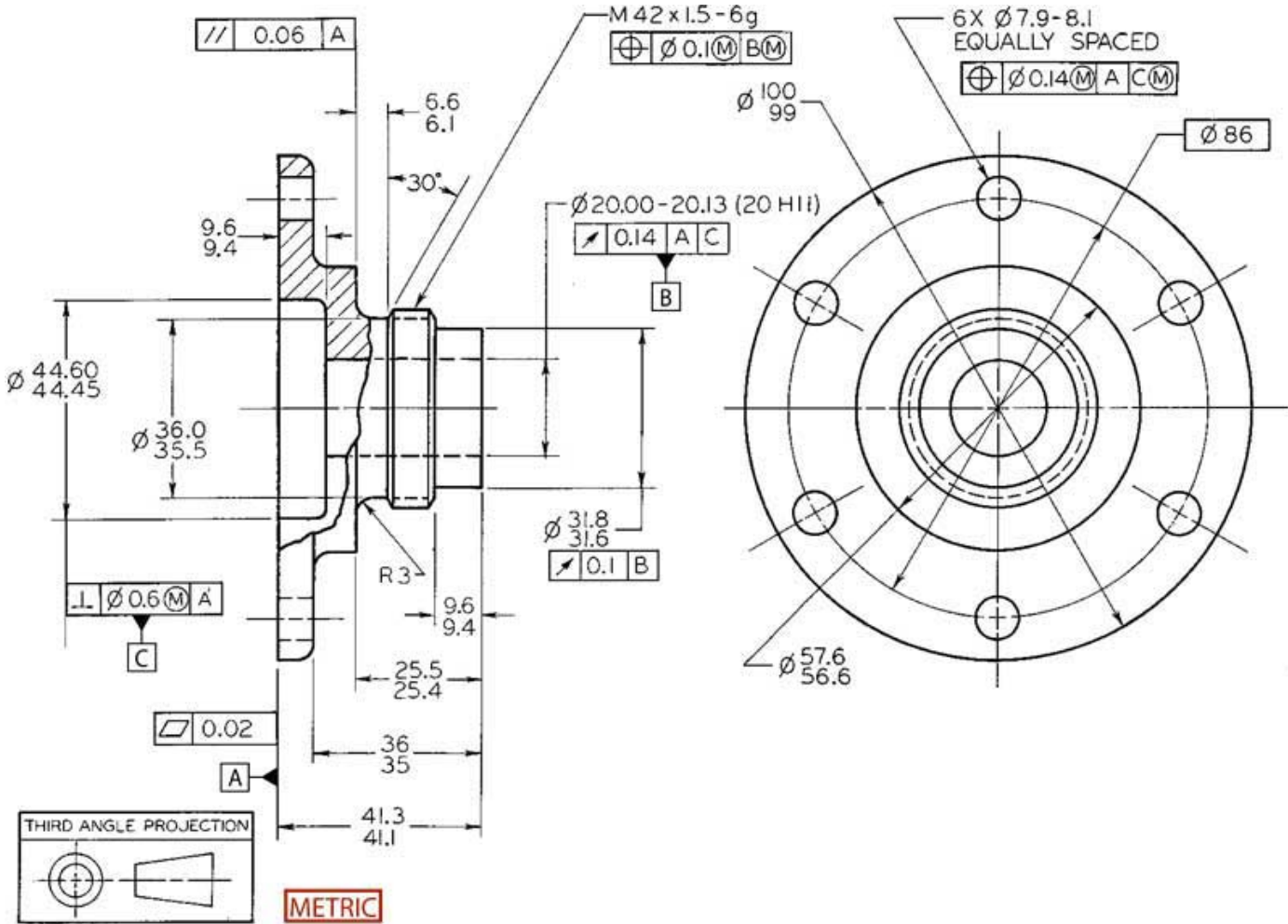

# GD&T







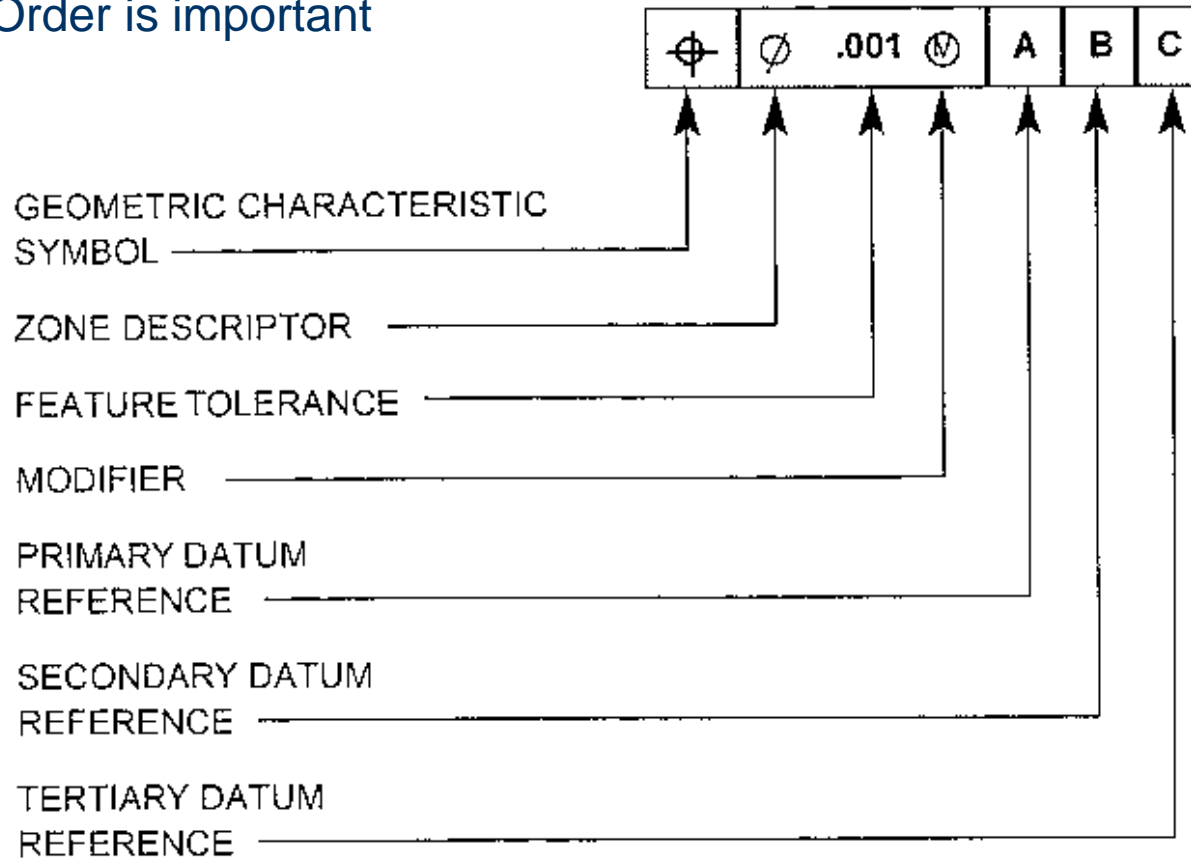





- GD&T described using feature control frame
- Need to understand:
  - Geometric Characteristics
  - Modifiers
  - Datums

# Feature Control Frame

Note: Order is important



# Geometric Characteristics

	TYPE OF TOLERANCE	CHARACTERISTIC	SYMBOL
FOR INDIVIDUAL FEATURES	FORM	STRAIGHTNESS	—
		FLATNESS	
		CIRCULARITY (ROUNDNESS)	
		CYLINDRICITY	
FOR INDIVIDUAL OR RELATED FEATURES	PROFILE	PROFILE OF A LINE	
		PROFILE OF A SURFACE	
FOR RELATED FEATURES	ORIENTATION	ANGULARITY	
		PERPENDICULARITY	
		PARALLELISM	
	LOCATION	POSITION	
		CONCENTRICITY	
		SYMMETRY	
	RUNOUT	CIRCULAR RUNOUT	
		TOTAL RUNOUT	



# Modifiers

- Symbols that help to define characteristics
  - Example: MMC – Maximum Material Condition-  
condition when most material exists

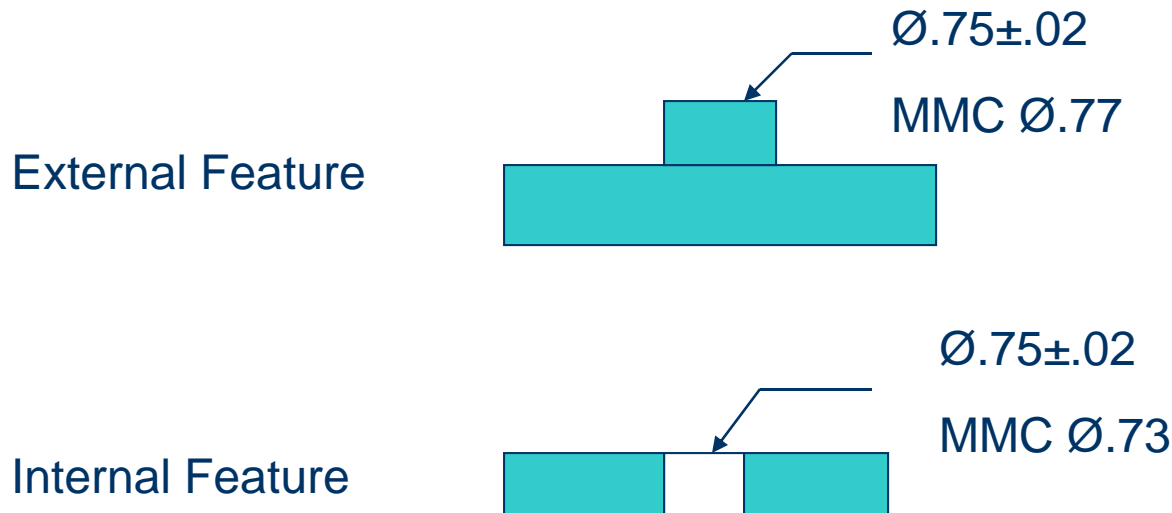

# Compare MMC to RFS (Regardless of Feature Size)



Produced size	Tolerance RFS	Tolerance MMC
1.002	.002	.002
1.001	.002	.003
1.000	.002	.004
.999	.002	.005
.998	.002	.006



# Straightness Example

THIS ON THE DRAWING

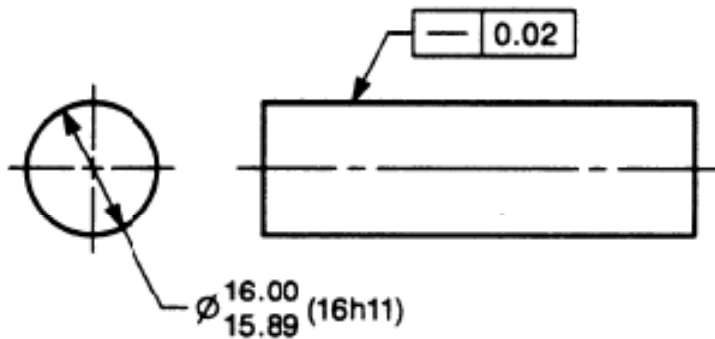

Each longitudinal element of the surface must lie between two parallel lines (0.02 apart) where the two lines and the nominal axis of the part share a common plane. The feature must be within the specified limits of size and the boundary of perfect form at MMC (16.00).

Note: Waisting (b) or barreling (c) of the surface, though within the straightness tolerance, must not exceed the limits of size of the feature.

MEANS THIS

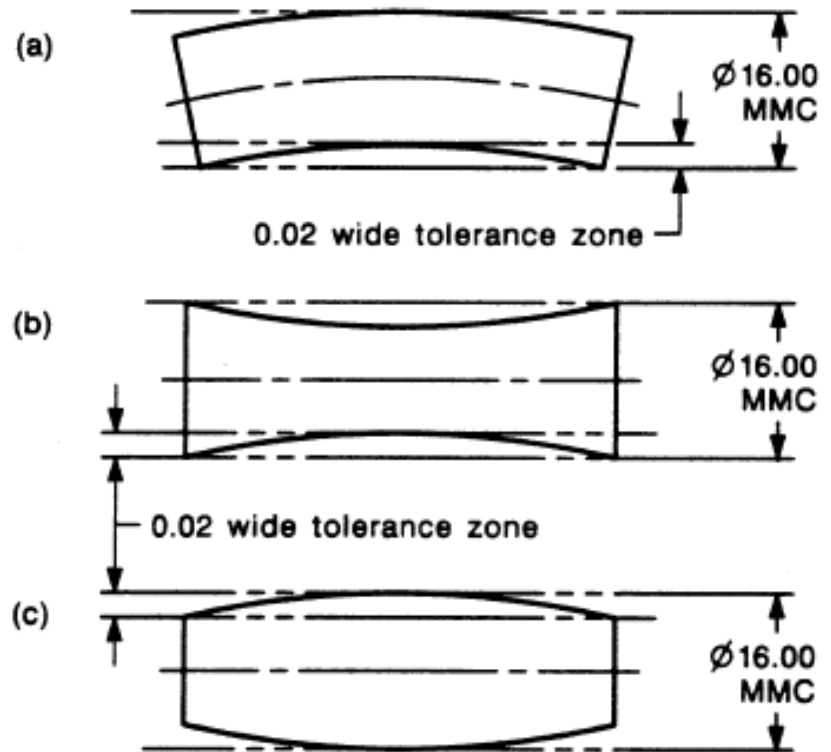

# Straightness at MMC

THIS ON THE DRAWING

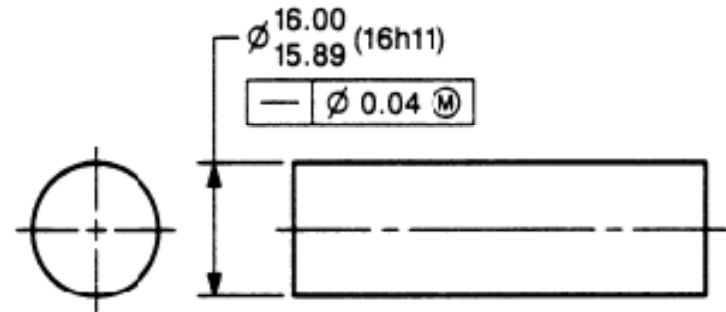

MEANS THIS

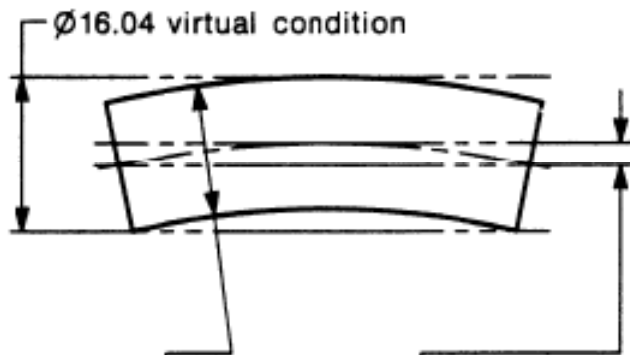

Feature size	Diameter tolerance zone allowed
16.00	0.04
15.99	0.05
15.98	0.06
↓	↓
15.90	0.14
15.89	0.15

ACCEPTANCE BOUNDARY

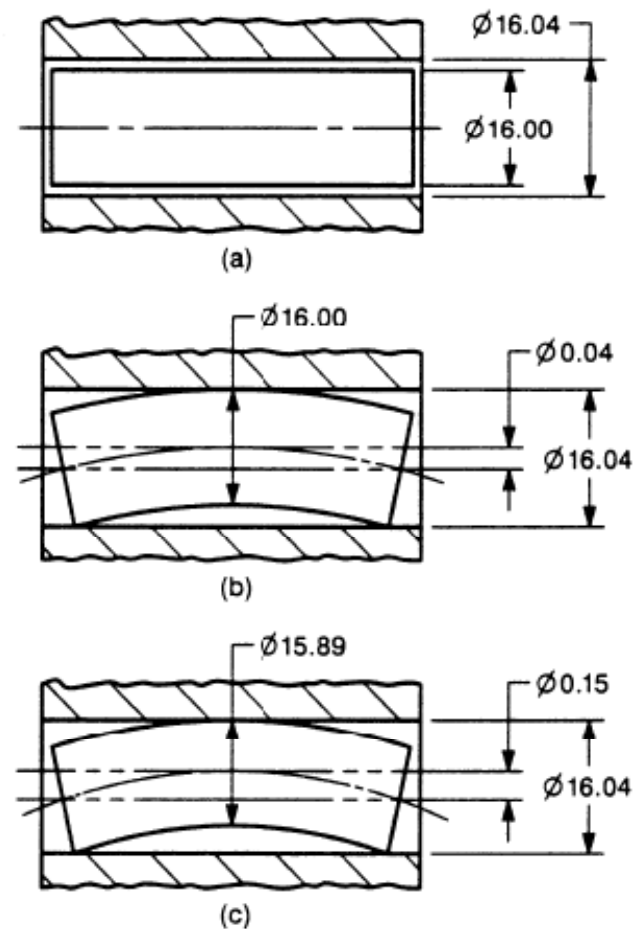

# Datums

- Theoretically perfect points, lines and planes used for reference.
- Again function of part very important
- Classified as primary, secondary or tertiary.

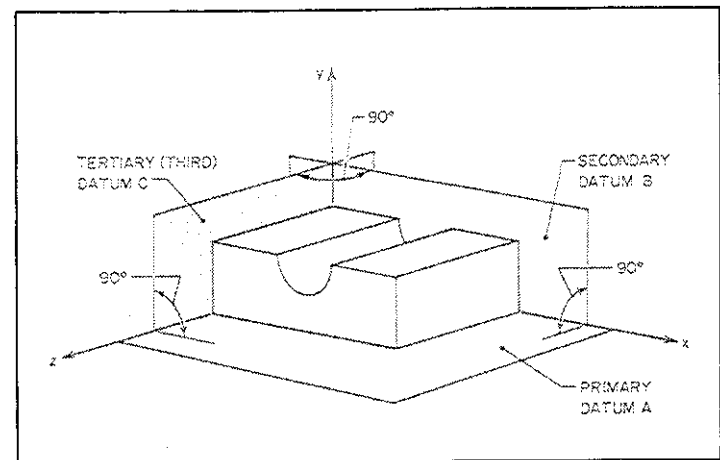
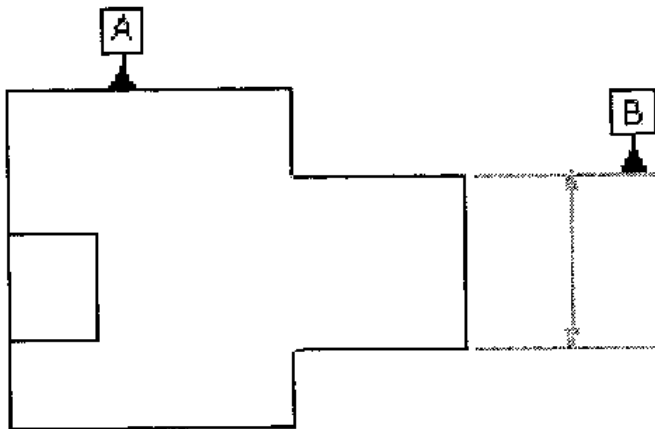

# Datum Surfaces and Features

- Datum surfaces and features are used as references to control other features

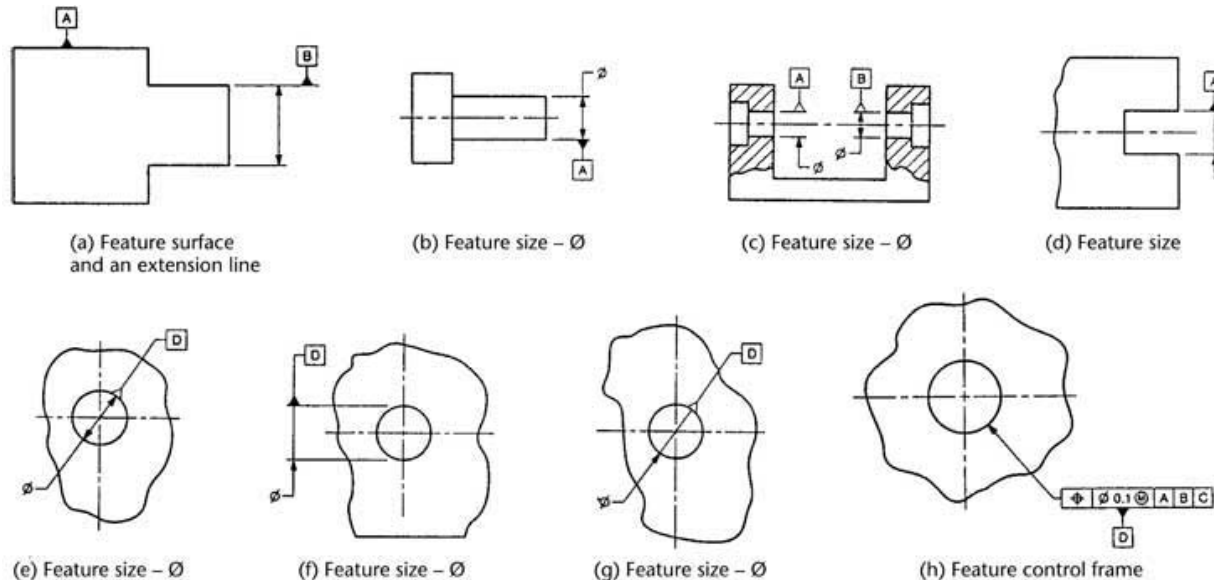

# Coordinate Tolerancing

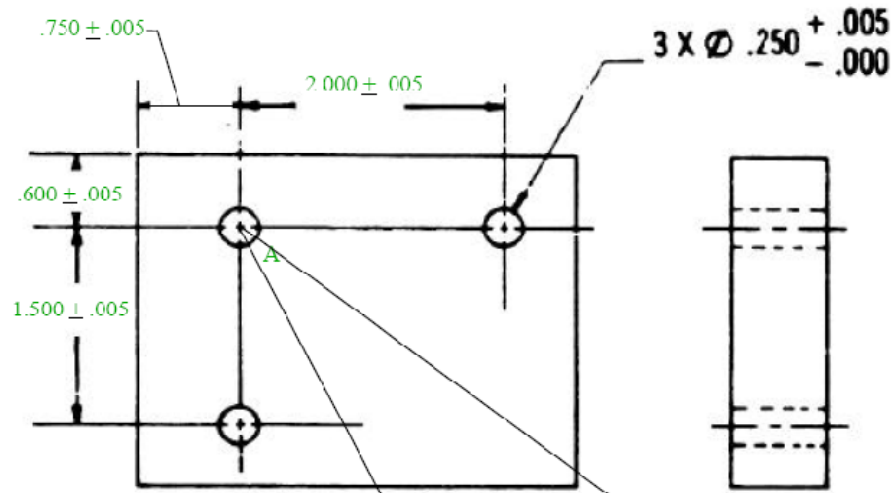

This dimensional tolerance controls the size of the 3 holes. The other dimensional tolerances control the positions.

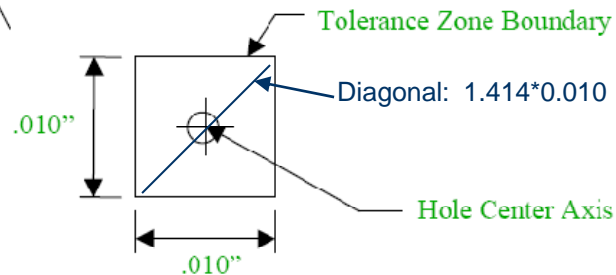

# Position Tolerancing

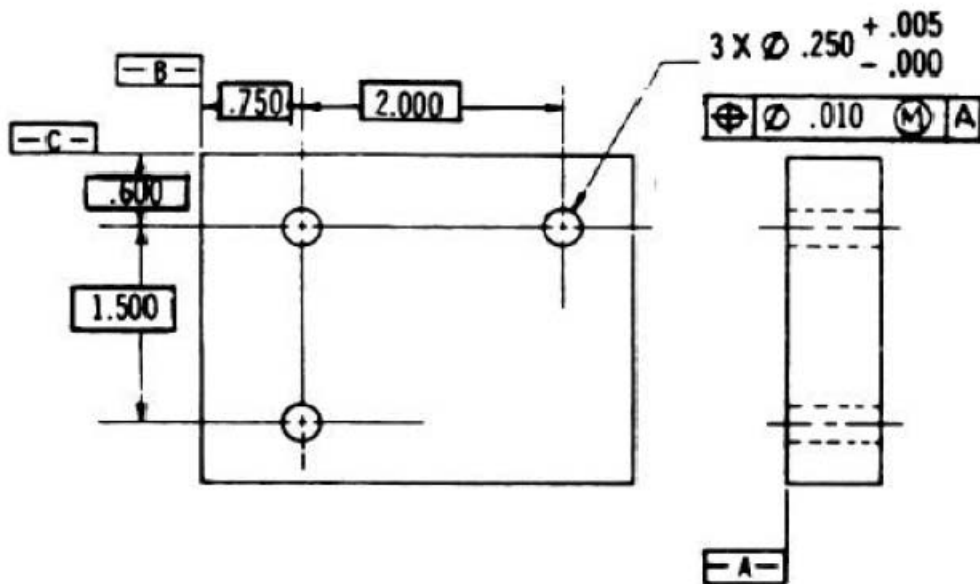

MMC of hole = .250

LMC of hole = .255

Hole diameter	Tolerance Zone
.250 (MMC)	.010
.251	.011
.252	.012
.253	.013
.254	.014
.255 (LMC)	.015

# True Position and Perpendicularity

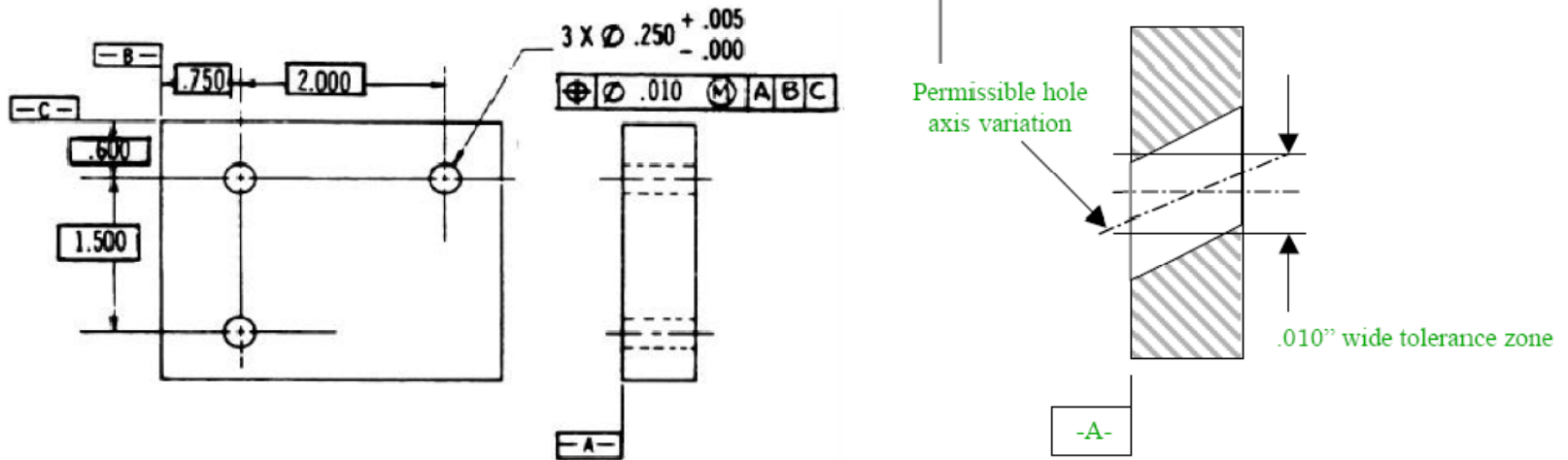

Referencing datum A means that the center axis of the hole must be perpendicular to datum plane A. The axis must intersect datum plane A inside the tolerance zone

# Using Geometric Dimensioning and Tolerancing

- Applying GDT principles requires:
  - Defining the part's functions
  - Listing the functions by priority
  - Defining the datum reference frame
  - Control selection
  - Calculating tolerances